

(12) UK Patent Application (19) GB (11) 2 107 927 A

(21) Application No 8228721
(22) Date of filing 7 Oct 1982
(30) Priority data
(31) 56/159967
(32) 7 Oct 1981
(33) Japan (JP)
(43) Application published
5 May 1983
(51) INT CL³
H01L 29/90 31/02
(52) Domestic classification
H1K 1DA 1DD 1EB 9B1
9B3 9M1 9N2 9N3 DAA
U1S 2208 H1K
(56) Documents cited
GB 1531633
EP A1 0001139
(58) Field of search
H1K
(71) Applicants
Kokusai Denshin Denwa
KK
(Japan),
2-3-2 Nishishinjuku,
Shinjuku-ku, Tokyo-to,
Japan

(72) Inventors
Yuichi Matsushima,
Kazuo Sakai,
Yukitoshi Kushiro,
Shigeyuki Akiba,
Yukio Noda,
Katsukuki Utaka
(74) Agents
Elkington and Fife,
High Holborn House,
52/54 High Holborn,
London WC1V 6SH

(54) Avalanche photodiode with quantum well layer

(57) An avalanche photodiode (APD) has a quantum well layer (13), in the form of a thin film, periodic multilayer (20, 21) structure composed of two different semiconductors e.g. InP/In_{0.53}

Ga_{0.47}As_{0.53} acting as a carrier multiplying region so that the effective ionization coefficient ratio of carriers is raised and only electrons of large ionization coefficient are injected therein, thus reducing noise in the APD. Incident light in the wavelength range 1.0 to 1.6 μm passes through a P-type InP layer (15) and is absorbed in the P-type In_{0.53}Ga_{0.47}As layer (14) to excite carriers. The excited electrons drift towards the quantum well layer (13) under the electric field of the pn junction (16), or, in an alternative embodiment, under the electric field of a pn junction between two InP layers provided on the quantum well layer (13). Other III—V compound semiconductors may be used and the APD may be of a planar construction.

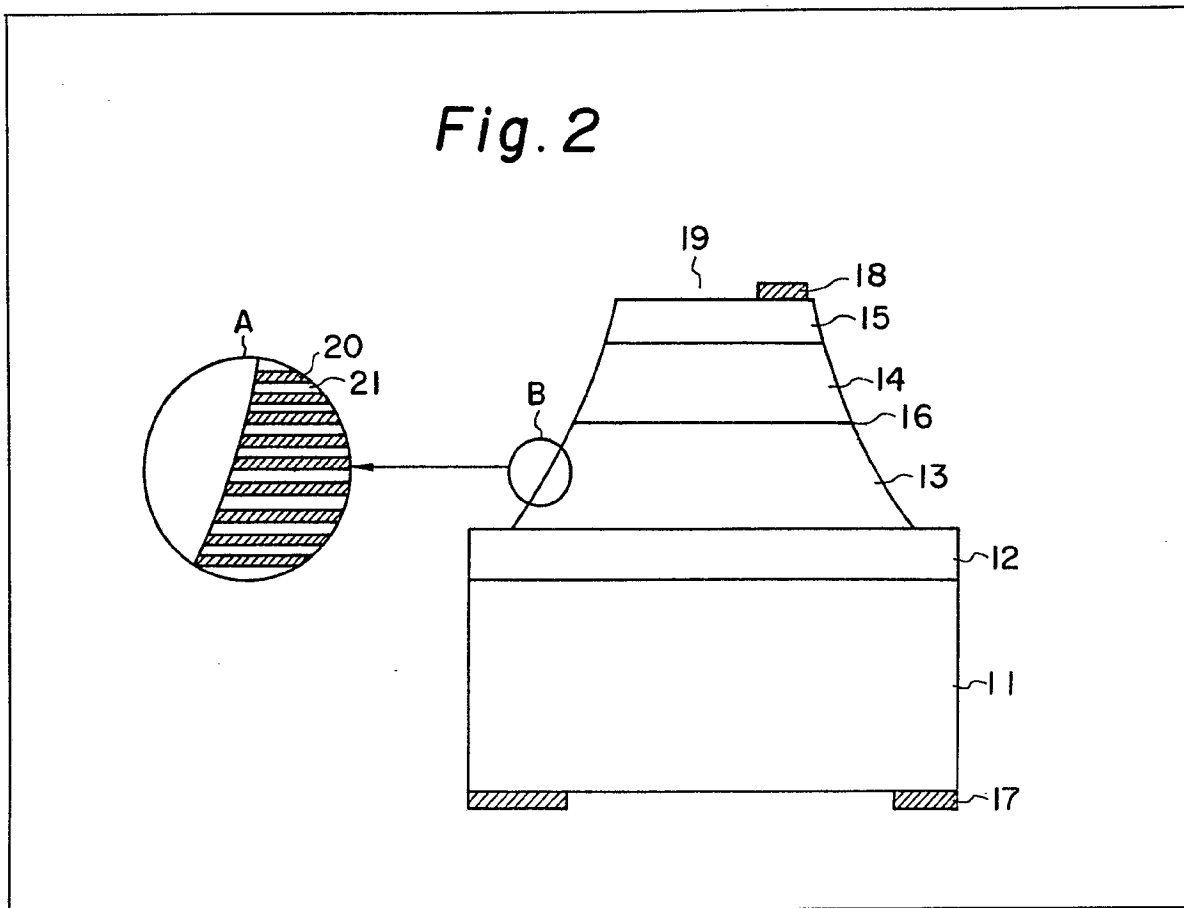

Fig. 1

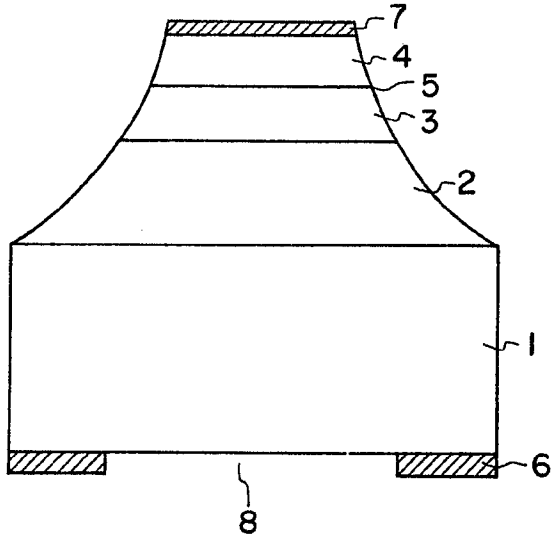

Fig. 2

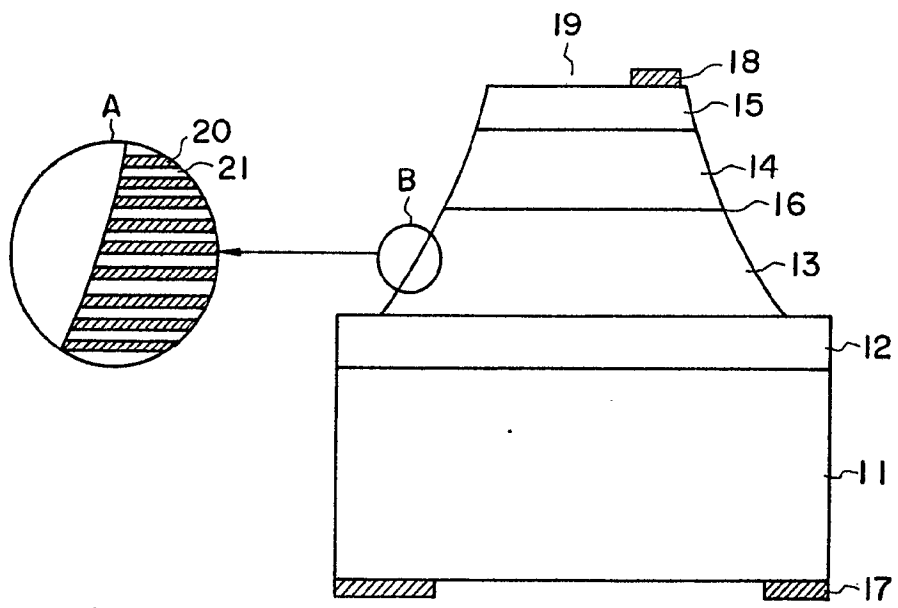

Fig. 3

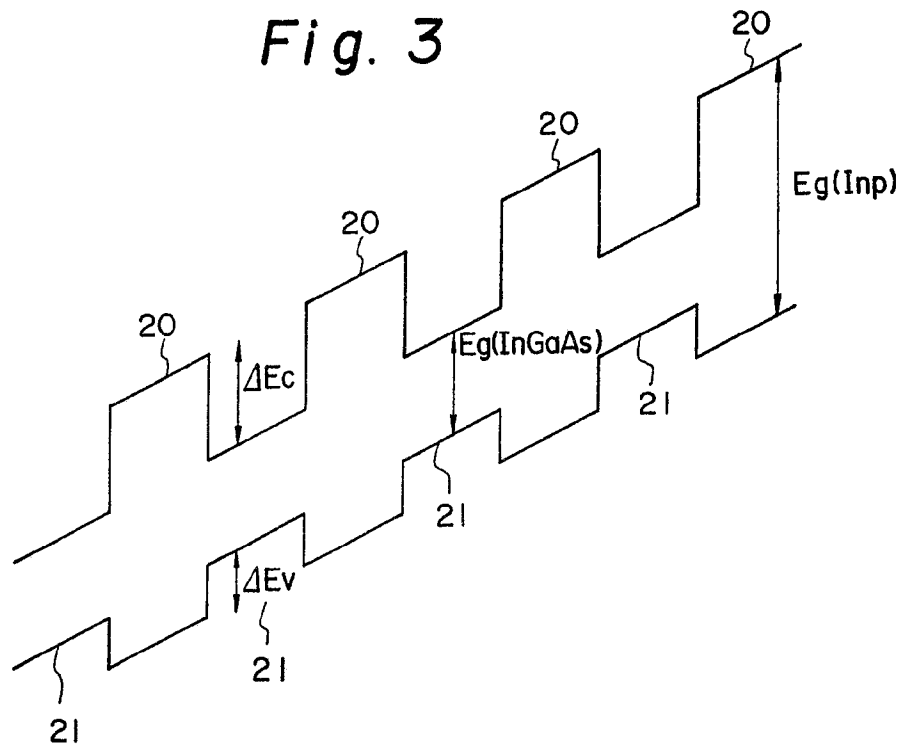
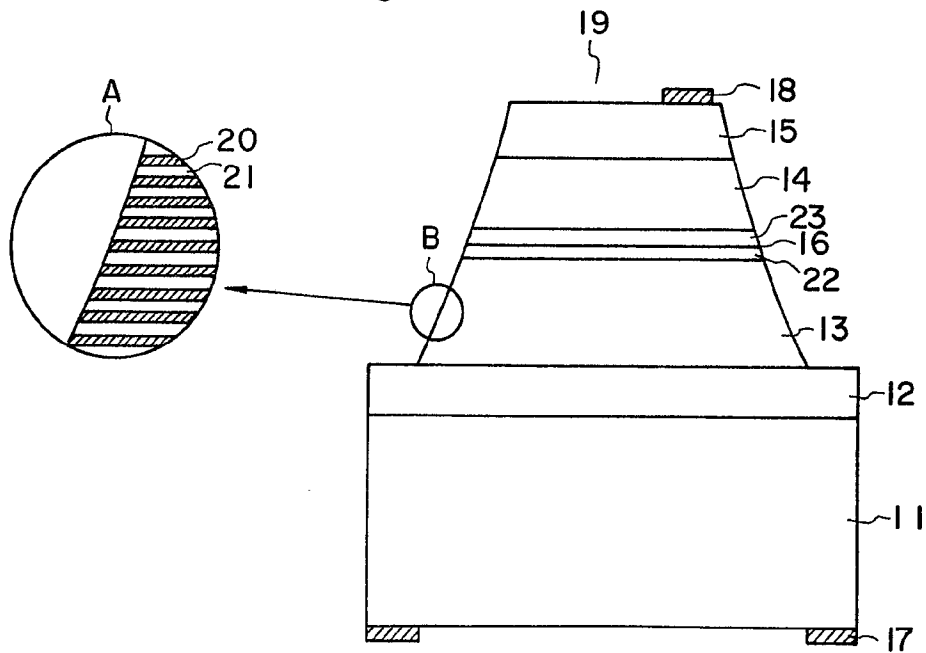

Fig. 4



SPECIFICATION

Avalanche photo diode with quantum well layer

The present invention relates to reduction of noise in an avalanche photodiode (hereinafter referred to as the "APD") of use in, for example, optical communication equipment or the like.

In the APD, carriers excited by incident light is accelerated and multiplied by a high intensity electric field emanating from a pn-junction but, due to fluctuation in this course of amplification, excess multiplication noise is produced. It is known that, letting the ionization coefficients of electrons and holes be represented by α and β , respectively, and assuming that the ratio therebetween is $k = \alpha/\beta$ or β/α , an excess noise factor decreases in proportion to the ratio k . Accordingly, in order to obtain an APD of low noise, it is necessary that the carriers of the larger ionization coefficient be injected into a material of a large ionization coefficient ratio k for multiplication.

At present, APDs using silicon crystals are widely employed as photo detectors in optical communications in the vicinity of a 0.8 μm wavelength region which utilize GaAs—AlGaAs system light emitting devices, but this is because silicon has as large an ionization coefficient ratio is $k = \alpha/\beta \approx 50$ and is suitable for use in the low-noise APD. However, the Si-APD cannot be used in a 1.0 to 1.7 μm wavelength range in which transmission loss of a silica fibre employed in optical communications is low. Heretofore, Ge-APD using germanium crystals has been employed as a photo detector having effective sensitivity to a 1 μm wavelength region, but since the ionization coefficient ratio of germanium is $k = \alpha/\beta \approx 1$, the Ge-APD suffers from large excess noise and cannot be regarded as an optimal photo detector. On the other hand, there are also under development APDs which use the III-V compound semiconductor crystals, such as InGaAsP, AlGaAsSb and so forth, and have effective photosensitivity to the 1 μm region. However, there is a limit to the decrease in noise in the APDs using such semiconductor materials in prior art.

It is an object of the present invention to provide an avalanche photodiode with a quantum well layer in which a thin film, periodic multilayer structure composed of two different semiconductors is formed in a carrier multiplying region; the effective ionization coefficient ratio of carriers is raised by a quantum well layer formed by the thin film, multilayer periodic structure, and only electrons of larger ionization coefficient are injected into the multiplying region, thereby to reduce noise in the APD.

In accordance with the present invention, there is provided an avalanche photodiode with a quantum well layer, comprising a first semiconductor layer for absorbing light to generate optically excited carriers; a quantum layer formed by a thin film, periodic multilayer

structure composed of second and third semiconductors for multiplying the optically excited carriers; and a pn-junction interposed between the first semiconductor layer and the quantum well layer.

In an embodiment of an avalanche photodiode with a quantum well layer of this invention, the pn-junction is formed in a semiconductor layer of a large forbidden band gap different from the first semiconductor so that only electrons may be injected into the quantum well layer.

Embodiment of the present invention will now be described, by way of example in comparison with conventional arts, with reference to the accompanying drawings, in which:

Fig. 1 is a longitudinal sectional view showing an example of a conventional avalanche photodiode;

Fig. 2 is a longitudinal sectional view illustrating one embodiment of the avalanche photodiode having a quantum well layer according to the present invention;

Fig. 3 is a schematic diagram showing the energy structure of the quantum well in the embodiment of Fig. 2 is a reverse biased condition; and

Fig. 4 is a longitudinal sectional view illustrating another embodiment of the present invention.

For ready understanding of the present invention, an example of the prior arts will first be described.

Of these prior art examples, an APD for the 1 μm wavelengths region, formed in $\text{In}_{0.53}\text{Ga}_{0.47}\text{As}/\text{InP}$, is shown in Fig. 1. In Fig. 1, reference numeral 1 indicates an *n*-type InP substrate; 2 designates an *n*-type $\text{In}_{0.53}\text{Ga}_{0.47}\text{As}$ layer; 3 identifies *n*-type InP layer; 4 denotes a *p*-type InP layer; and 5 represents a pn-junction. Light 8 of 1 to 1.6 μm wavelength, incident on the side of the substrate, passes through the substrate and is absorbed in the $\text{In}_{0.53}\text{Ga}_{0.47}\text{As}$ layer 2 to excite carriers. The carriers excited in a reverse-biased condition in the vicinity of breakdown drift due to a high intensity electric field set up by the pn-junction 5 in the InP and they are multiplied in the InP layer 4. The excess noise in this APD is dependent on the ionization coefficient ratio k of the multiplying region, that is, the InP. According to reports published so far, since the ionization coefficient ratio k of this InP, β/α , is approximately equal to 2, the APD shown in Fig. 1 is low-noise as compared with the Ge-APD but apparently inferior to the Si-APD in terms of noise. Also in the III-V compound semiconductors other than the abovesaid InP, there is no material in which the ionization coefficient ratio k is approximately equal to that of silicon; accordingly, there is a limit to the reduction of noise in the APDs using such semiconductor materials.

Next, details of embodiments of the present invention will be described in connection with those using the InP-InGaAsP alloy material.

Fig. 2 is a cross-sectional view of one embodiment of the present invention. An *n*-type

InP layer 12 having an impurity concentration of $5 \times 10^{17} \text{ cm}^{-3}$ and a thickness of $5 \mu\text{m}$ is formed on an n -type InP substrate 11 having an impurity concentration of $1 \times 10^{18} \text{ cm}^{-3}$, and a quantum well layer 13, which is composed of 50 n -type InP layers 20 (each 400 \AA thick layer) having an impurity concentration of $3 \times 10^{15} \text{ cm}^{-3}$ and 50 n -type $\text{In}_{0.53}\text{Ga}_{0.47}\text{As}$ layers 21 (each 600 \AA thick layer) formed alternately with each other, is formed on the n -type InP layer. Further, a p -type $\text{In}_{0.53}\text{Ga}_{0.47}\text{As}$ layer 14 having an impurity concentration of $5 \times 10^{16} \text{ cm}^{-3}$ and a thickness of $2 \mu\text{m}$ and a p -type InP layer 15 having an impurity concentration of $1 \times 10^{18} \text{ cm}^{-3}$ and a thickness of $1 \mu\text{m}$ are formed on the quantum well layer. In Fig. 2, a circle A is an enlargement of a circle B which is a part of the thin film multilayer periodic structure, and reference numerals 17 and 18 indicate metal electrodes. For the formation of such a semiconductor multilayer structure as shown in Fig. 2 on the InP substrate, use is made of a crystal growth method which is excellent in film thickness controllability, such as a molecular beam epitaxial method, a vapour epitaxial method or a vapour deposition method utilizing an organic metal. Incident light 19 having a wavelength of 1 to $1.6 \mu\text{m}$ passes through the p -type InP layer 15 and is absorbed by the p -type $\text{In}_{0.53}\text{Ga}_{0.47}\text{As}$ layer 14 to excite carriers therein. When a reverse bias is being applied, holes of the excited carriers flow towards the electrode 18 while electrons drift by an electric field caused by the pn-junction 16, and they are injected into the quantum well layer 13 of the thin film multilayer structure and multiplied in this high intensity electric field region.

The multiplication of the carriers by the high intensity field in such a quantum well layer 13 is described in IEE Electronics Letters, 16, P467 (1980). According to this literature, the effective ionization coefficient ratio $k = \alpha/\beta$ by the quantum well layer 13 markedly increases, for the following two reasons, as compared with the ionization coefficient ratio inherent to the material forming the quantum well layer 13.

(1) Fig. 3 is an energy band of the quantum well layer 13 of this embodiment in the reverse-biased condition, $E_g(\text{InP})$ and $E_g(\text{InGaAs})$ being the forbidden band gaps of the InP and the $\text{In}_{0.53}\text{Ga}_{0.47}\text{As}$, respectively, and ΔE_c and ΔE_v being discontinuous energies on the sides of the conduction and the valence bands resulting from the difference being the forbidden band gaps of the InP and the $\text{In}_{0.53}\text{Ga}_{0.47}\text{As}$. Consequently, the relation $\Delta E_c + \Delta E_v + E_g(\text{InGaAs}) = E_g(\text{InP})$ holds and $\Delta E_c > \Delta E_v$. The electrons injected from the InP layer 20 into the $\text{In}_{0.53}\text{Ga}_{0.47}\text{As}$ layer 21 have the high energy ΔE_c , whereas holes have a low energy ΔE_v , causing an increase in the ionization coefficient α of the electrons.

(2) In the quantum well layer 13, the hole-hole collision increases more than the electron-electron collision and the holes are confined in the well of the valence band more than the electrons. As a result, of this, ionization of the electrons effectively increases as compared with the

ionization of the holes. The effective ionization coefficient ratio $k = \alpha/\beta$ in the quantum well layer 13 depends on the intervals of the individual periodic structures, the number of layers of each kind and the impurity concentration of each layer but can be set to $k = 10$ to 30 .

The electrons multiplied in the quantum well layer 13 having such a large ionization coefficient ratio flow towards the electrode 17, from which an amplified current signal is delivered to an external terminal. In this case, since the ionization coefficient ratio of the quantum well layer 13 which is the multiplying region is large as described above, the excess multiplication noise is far lower than in the case of the APD using a simple III-V compound semiconductor such as InP for the multiplication.

Fig. 4 is a cross-sectional view illustrating a second embodiment. This embodiment differs from the first embodiment of Fig. 2 in that the pn-junction provided on the quantum well layer 13 is formed by an n -type InP layer having an impurity concentration $3 \times 10^{15} \text{ cm}^{-3}$ and a thickness of $0.5 \mu\text{m}$ and a p -type InP layer 23 having an impurity concentration of $5 \times 10^{16} \text{ cm}^{-3}$ and a thickness of $0.3 \mu\text{m}$. In this embodiment, since the pn-junction 16 which becomes a point of the highest field intensity is defined by the InP layers 22 and 23, the field intensity which is applied in the $\text{In}_{0.53}\text{Ga}_{0.47}\text{As}$ layers 14 and 21 of small forbidden band gap is alleviated and dark current components, such as a tunnel current and a generation-recombination current in the $\text{In}_{0.53}\text{Ga}_{0.47}\text{As}$ layers, can be decreased, permitting further reduction of noise in the photo detector. Moreover, this embodiment is also identical with the first embodiment in the process of electrons being injected into the quantum well layer having a large ionization coefficient ratio and multiplied therein.

In the foregoing embodiments, it is shown that a high sensitivity and low-noise avalanche photodiode having effective sensitivity to light of a 1.0 to $1.6 \mu\text{m}$ wavelength can be obtained by using the $\text{In}_{0.53}\text{Ga}_{0.47}\text{As}$ layer as a region for absorbing light and for exciting carriers and by using the quantum well layer composed of the $\text{In}_{0.53}\text{Ga}_{0.47}\text{As}$ layer and the InP layer as a region for multiplying the electrons injected thereto.

However, the present invention is also applicable to the III-V compound semiconductors. AlGaAs-GaAs, AlInGaAs-InP, InGaAsP-InP, AlGaAsSb-GaSb systems. Furthermore, it is also possible to employ semiconductors reverse in conductivity type from those used in the embodiments. Moreover, the embodiments have been described in respect of APDs of the mesa structure, but a planar structure can also be employed.

As has been described in the foregoing, according to the present invention, a large ionization coefficient ratio which could not have been obtained with a simple III-V compound semiconductor is obtained through the use of the quantum well layer, and only electrons are injected into the quantum well layer used as a

5 multiplying region, so that an extremely low-noise avalanche photodiode can be obtained; therefore, the present invention is of great utility when employed in for example, optical communications and so forth.

CLAIMS

10 1. An avalanche photodiode, comprising a first semiconductor layer for absorbing light to generate optically excited carriers; a quantum well layer formed by a thin film, periodic multilayer structure composed of second and third semiconductors for multiplying the optically

excited carriers; and a pn-junction interposed between the first semi-conductor layer and the quantum well layer.

15 2. An avalanche photodiode according to claim 1, wherein the pn-junction is formed in a semiconductor layer of a large forbidden band gap different from the first semiconductor so that only electrons may be injected into the quantum well layer.

20 3. An avalanche photodiode with a quantum well layer substantially as herein described with reference to Figures 2 and 3 or 4 of the accompanying drawings.